



JVMR Industries

C04, HMT Industrial Estate

Jalahalli, Bangalore 560 031

Ph. No. +91 7829000525/515

Email: jvmrindustries@rediffmail.com

Website: www.jvmrindustries.com

An ISO9001-2008 company



JVMR Industries is a Proprietary firm which has emerged as a dependable Material Handling Equipments, precision Engineering components, Jigs, Fixtures, MS & SS Fabrication company.

JVMR has to its credit a good backup of technical entrepreneurs who has about 20 years of functional experience in various types of Engineering Industries & experienced work force.

Location



Our industry is centrally located at HMT Industrial Estate with 5500sqft of covered floor area and 15000 sqft of open area located close to Peenya which houses good no of small industries with infrastructure for all types of processes.

We are equipped with good infrastructure facilities for Design & Manufacture and are having access to other special requirements within our close proximity.

Products & Services



We take pride in introducing ourselves as a company engaged & specialized in Manufacturing of Material Handling Equipments, precision Engineering components, Dollies, Pallets, Flow racks, Special purpose jigs & Fixtures, Roller Conveyors, Sub Assemblies, MS & SS Fabrication

Our industry has etched a respectable place in the market with a team of good experienced engineers.

We have in house facility to fabricate, machine and assemble as per customer requirements.



Design Support Advance Technologies

Engineering & Design

Design capability is one of the core strengths of the team. A strong manufacturing background enables the team to offer practical solutions designed for manufacturability.

Design capabilities of the team encompass all the related manufacturing areas – welding of automotive components, wiring harnesses, connectors, terminals, moulded plastic components, Aluminum casting, injection moulding tools, rear vision systems and complete module designing.

Services offered:

- Product Engineering
- Reverse Engineering
- Prototype, Jigs & Fixtures Services
- Testing and Documentation
- Proto development & Support
- Value Added Services
- Tooling & Manufacturing support



Instrument panel design



Steering and panel integration

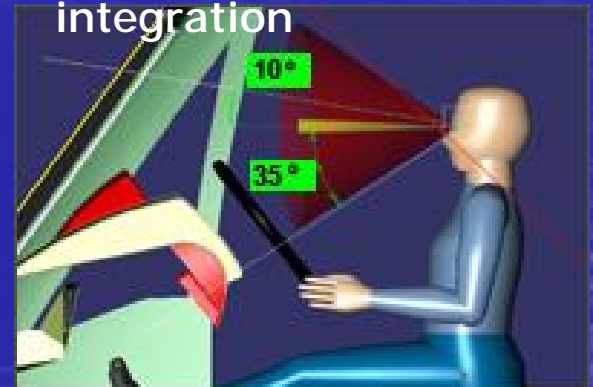

Ergonomic & Visibility

HMI Display

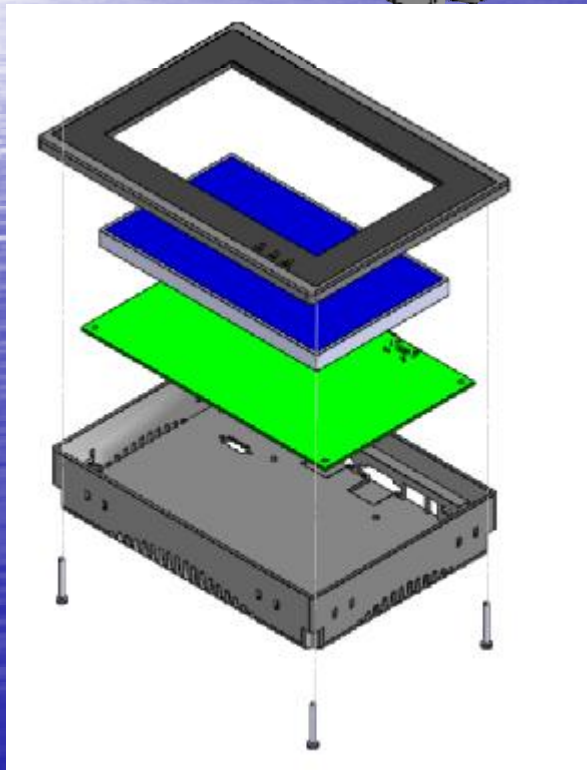
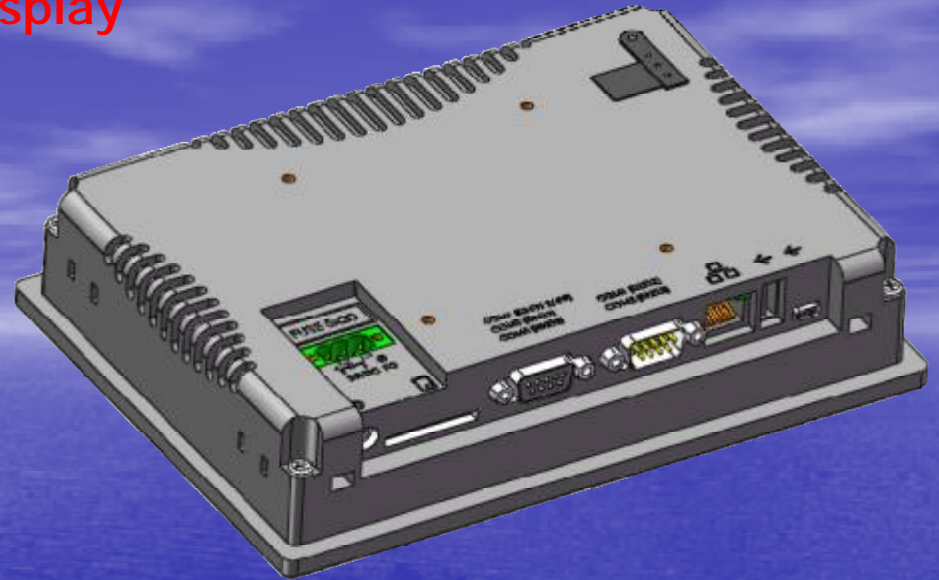
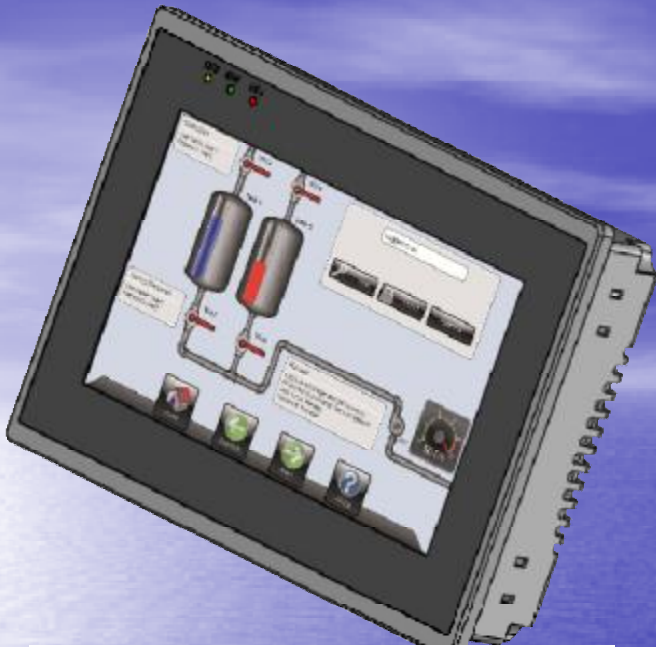

- Enclosure to meet IP65
- Rugged Application
- EMI/EMC shielding solution
- To meet Environment compliance tests
- Designed in order to protect from harsh environmental conditions

HMI Display

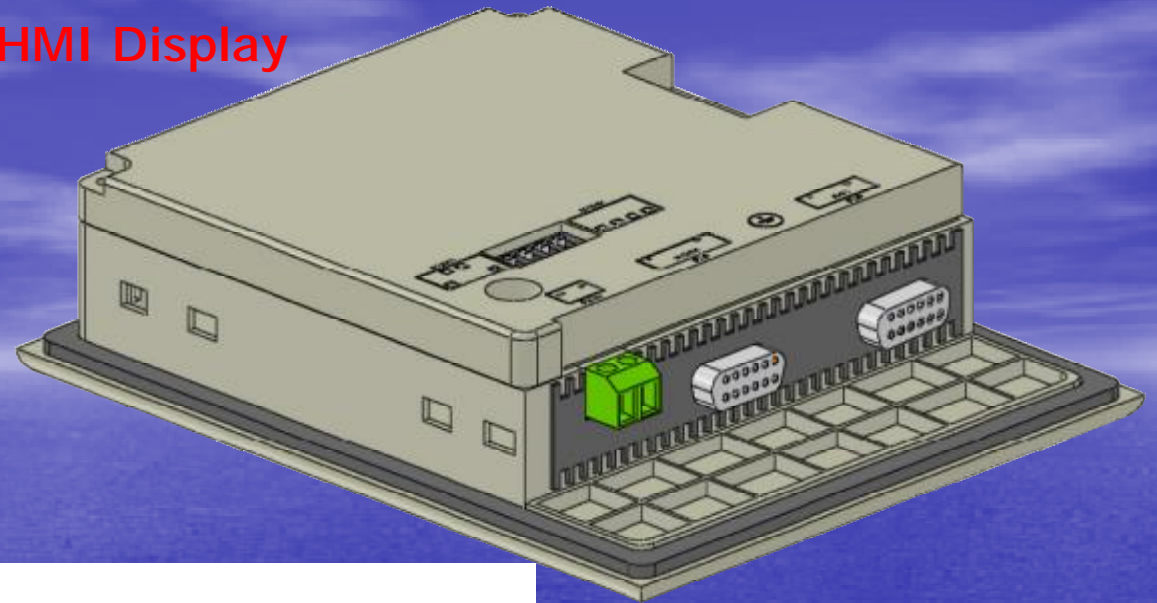
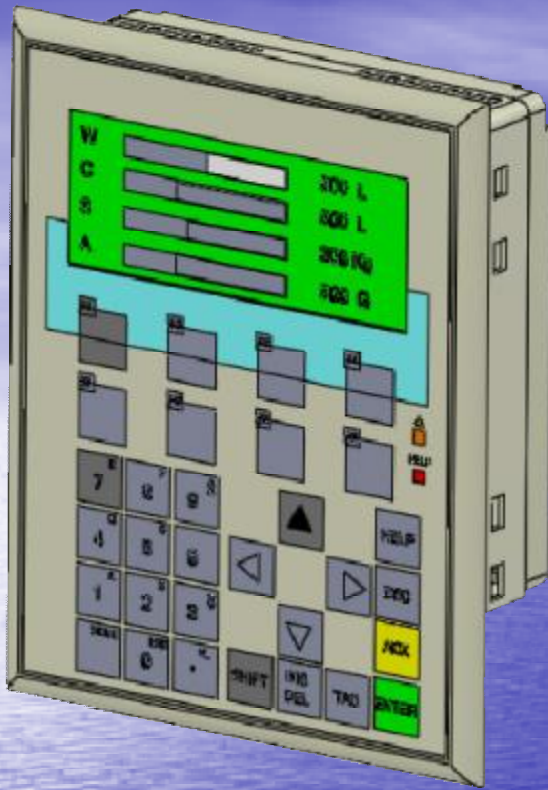

- Enclosure to meet IP65
- Rugged Application
- EMI/EMC shielding
- To meet Environment compliance tests
- Designed in order to protect from harsh environmental conditions

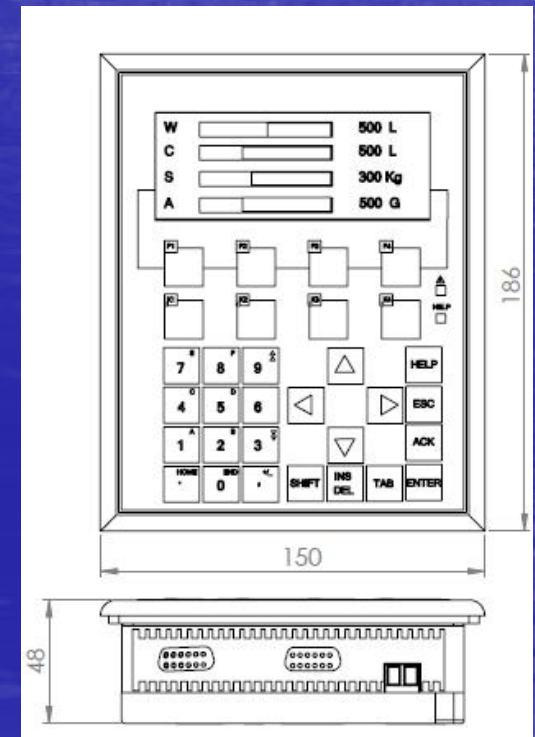
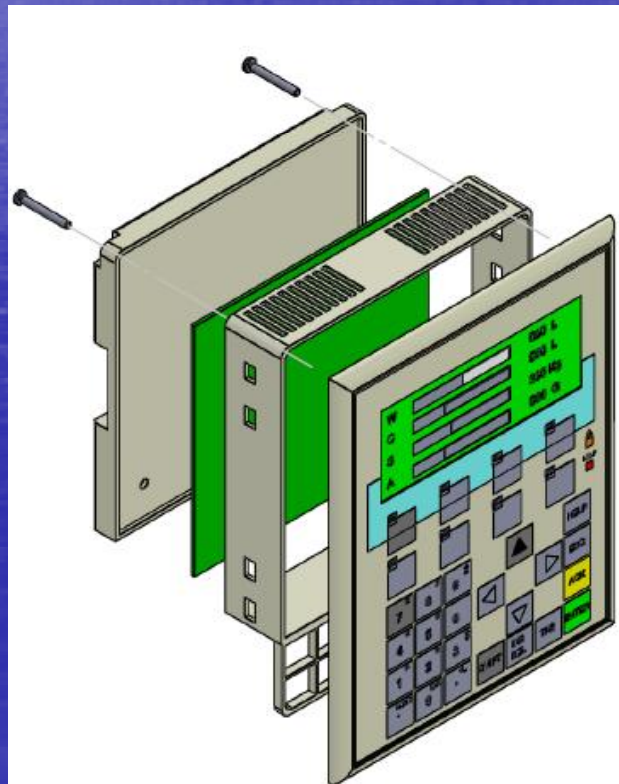

Concept & Mechanical detailing for forklift

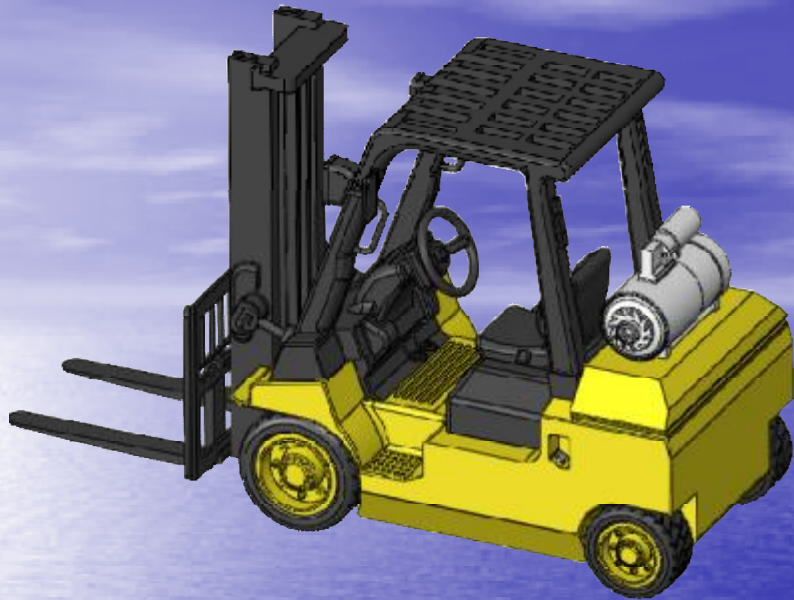

- An innovative operator compartment design offers easy driver access, excellent all-round visibility and conveniently located controls
- Optimized driver comfort, full-suspension seat, achieving a low whole body vibration (WBV) and operator ear noise levels are low
- Complete service access contributes to efficient maintenance. Simplified wiring and offers greater access to components, which decreases service time and regular maintenance

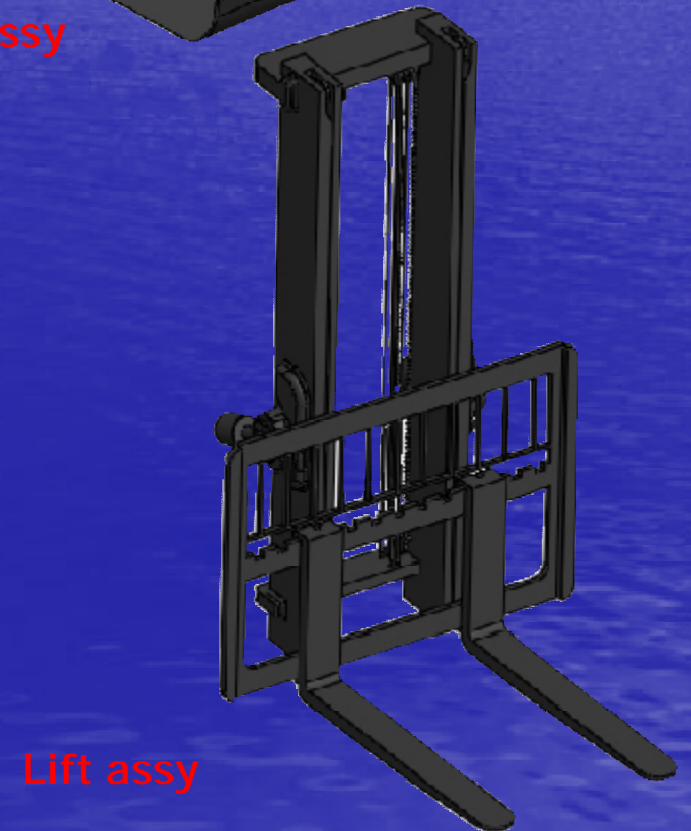

Concept & Mechanical detailing for wheel loader HMI & Mounting



Wheel loader with HMI

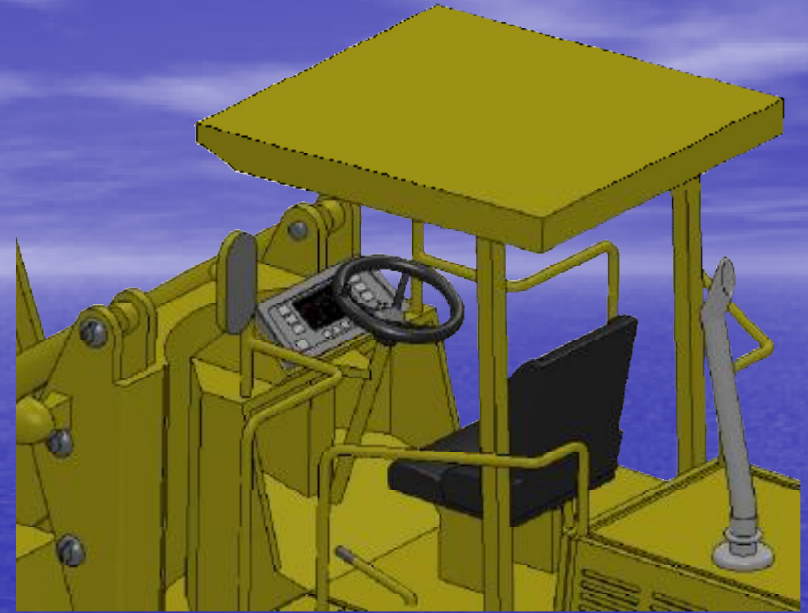

HMI mounting on wheel loader

- HMI Design capability enables a visibility from various positions
- Heavy –duty design provides protection
- Ergonomic study of operator area
- Visibility study inline with construction equipment
- Heat shield and sealing design to meet NVH requirement
- Integration of seat assembly and side console
- Design and routing of harness using 3D tool
- HMI enclosures designed in order to protect them from harsh environmental conditions.

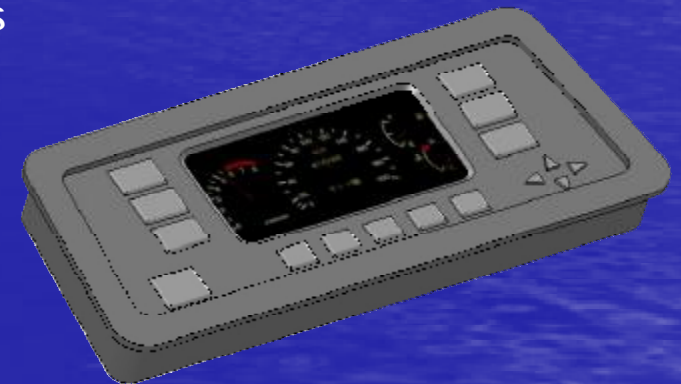

HMI assembly

Instrument cluster design:



- Intuitive console design
- All controls easily accessible
- Ergonomic study of operator area
- Easy side to side movement for good all round visibility
- Cable harnessing & Routing
- Design for Manufacturing (DFM) and Tooling
- Proto development process and assembly
- Vehicle integration & Testing

Ergonomic Analysis

Ergonomic characteristics of products in the design phase

Vision field analysis

Instrument panel

Seat Assembly

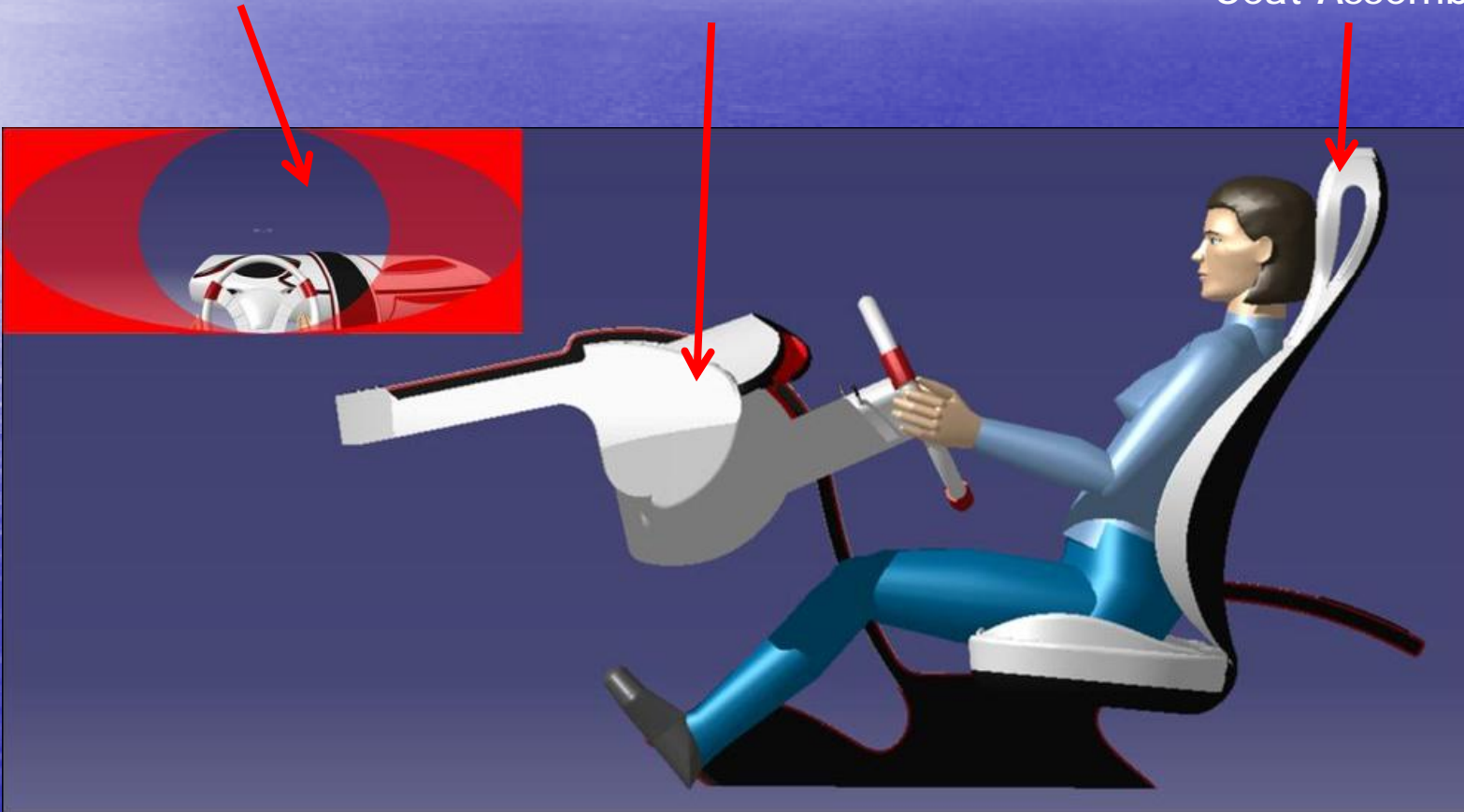

IEC Fixture development and Testing (ISO 16750-3)

Testing setup



Shock load testing



Concept design for Automotive

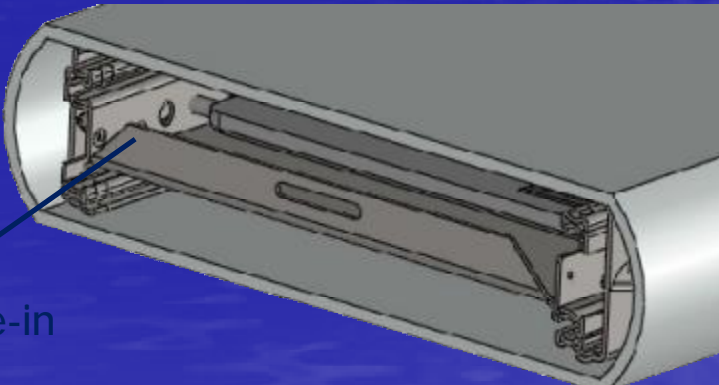
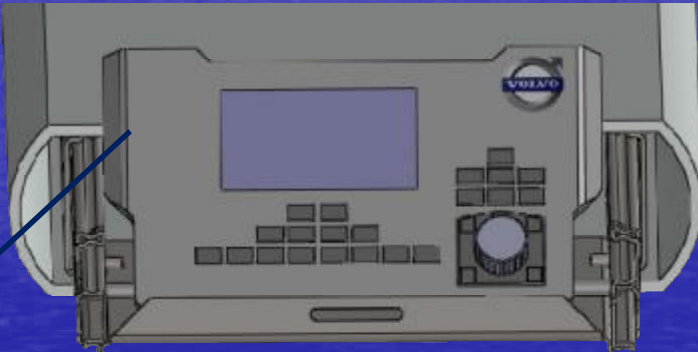
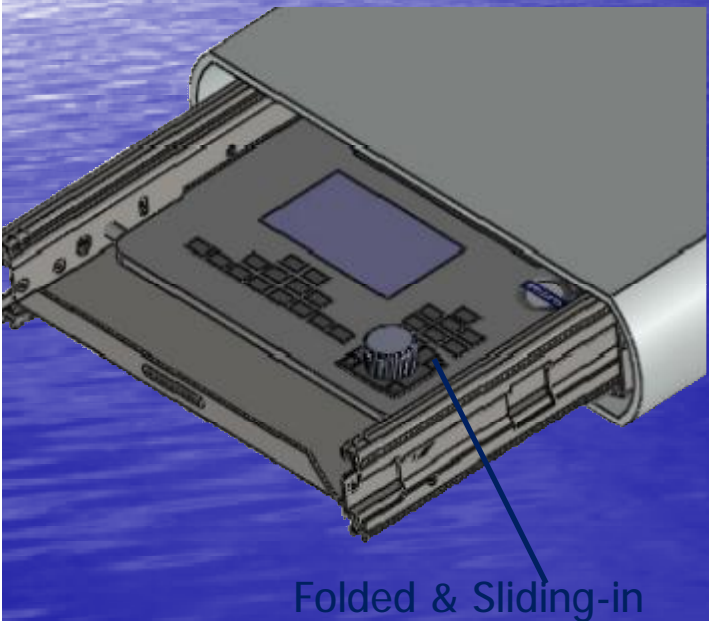
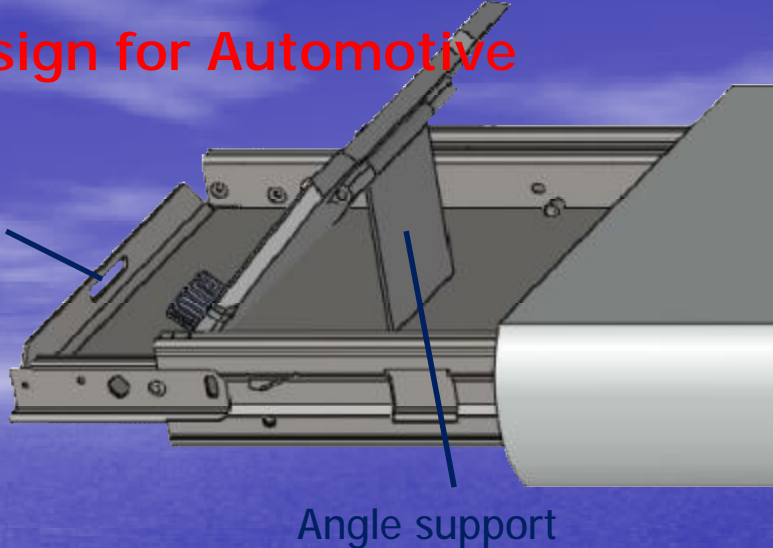
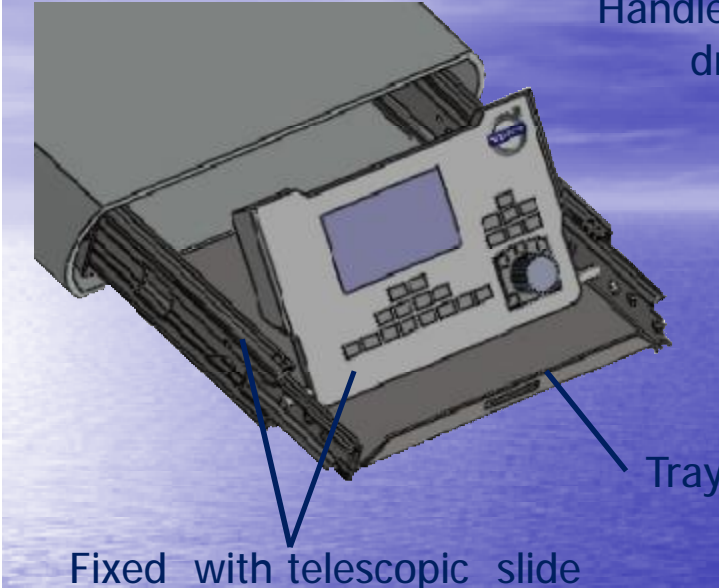

Resources:

Engineering manager:

Qualification: Masters in Product Design(Automotive)

Total experience: 16+ years

Team Lead:

Qualification: Bachelor of engineering in Product Design & Diploma in Product engineering

Total experience: 8 years

Designers:

Bachelor of engineering in Product Design

Total experience: 4 to 6 years

Analysis Engineer:

Qualification: Masters in Analysis(Thermal & Vibration)

Total experience: 8+ years

Software Skills



Major clients – Design Services

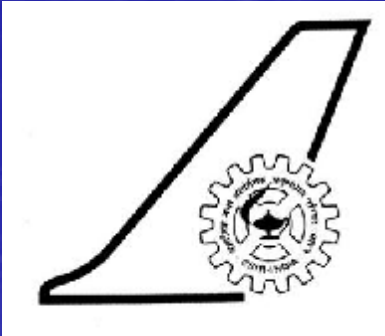

Esteemed Customers- Products



We have earned our customers trust which has been a fine reward for our endeavors.

The unmatched quality for our end product and services has earned us a wide base of clientele like

- ✓ Integral Coach Factory, Chennai – MS Seat Frames, Fuel Tanks, Mirror Assy, SS Tanks & Partition Frames with Honey Comb panels and other general MS & SS Fabrication Items.
- ✓ South Western Railways – Mirror Assy, Fuel & Water Tanks and other MS & SS Fabricated Items.
- ✓ Advics South India Limited – Roller Conveyors, Trollies, Inspection tables & Other material handling equipments.

Esteemed Customers - Products



- ✓ Toyota Group – Roller Conveyors, Fixtures, Trolleys, Display Stands & Boards.
- ✓ Honda Motor Cycle & Scooter India Pvt Ltd – Dollys for Assy Plant.
- ✓ Conergy Energy Systems Pvt Ltd - Solar Panel Structures & Press Parts .
- ✓ Geotrix Building Envelope Pvt Ltd – Brackets & Structures for building enclosures.
- ✓ SVB Industries – Railway Seats & other parts for Indian railways.
- ✓ Webb India Private Limited - Conveyor Components, Shafts, Pins & M/c of Castings
- ✓ Primo Automation Systems P Ltd – Welding Automation Sub Assemblies & Fixtures.
- ✓ Disa India Private Limited – Components for Foundry Equipments
- ✓ VECTRA Group - Fabricated & Press parts for Passenger Bus Seating systems & various defense equipments.
- ✓ Blue Star Ltd – Manufacture & Erection of super structures for their construction at Mantri Square at Malleswaram.

Inspection Facilities



Verniers – 0 to 150mm – 2nos

Verniers – 0 to 300mm – 2nos

Verniers – 0 to 600mm – 1no

Digital Verniers – 0 to 150mm - 2nos

Micrometer 0 - 150mm – 1set

Bore Gauge with Dial Indicator – 1set

Surface Plate 1000 x 1000 mm & 1000 x 2500 mm – 1 Each

Slip Gauges 1 Set, Height Gauge 600mm - 1 No

Depth Gauge 200mm – 1 No, Magnetic Film Thickness Gauge – 1No.

And other instruments in regular use.

Production Facilities



Heavy Duty Drilling Machine 1" Cap - 1no

Drilling Machine 12mm Cap – 2nos

Lathe 8 feet – 1no

Essab/ Advani / Protech MIG Welding Machine 400Amps – 9nos

Tig Welding Machine 250Amps – 1no

Heavy Duty Arc Welding Machine Oil Cooled 300amps– 1no,

Arc Welding Machine 200Amps – 1no

Gas Cutting Set – 1no, Pug Cutting Set – 1no, Chop Saw – 2nos, Bench Grinder - 1 No

Surface Grinding machine 1000mm stroke – 1 No

Energy Make Press Brake to bend 2500mm lg (6mm Thick) – 1 No

Ravi Make Shearing Machine to shear 2500mm lg (6mm Thick) – 1 No

Sailesh Make Mechanical Power Press 30MT – 1 No.

Production Facilities



Fly Press No.12 – 1 No, Power Hack Saw – 1 No.

Hand Shear – 1 No, Fly Press No.16 – 1 No.

SS Buffing machine – 1 No.

MS Belt Sandering Machine – 1 No.

Plywood Cutting machine with Bed (8x4) – 1No.

Portable Plywood / LP Sheet Cutting machine – 1 No.

Handling Facility – 2.5MT Hydraulic Pallet Truck & 5MT Chain Pulley with A frame & other small hand tools like grinders, drilling m/c , Jig saw, Battery operated nut runners, Air Compressor, etc.

Work Force



Supervisor & QC – 3 nos

Turner - 1 no

Milling Operator – 1no

Helpers – 7nos

Admin Staff – 1 no

Fitter – 2 no

Welder - 5 nos

Sales & Marketing – 1 no

Fitters, Welders & Helpers on contract for site work from our labor contactor on need basis.



MANUFACTURING AND QUALITY CONTROL

At JVMR quality control begins with inspection of all incoming materials. Utmost attention is extended through out all process of manufacturing like material storage/handling, machining, fabrication, assembly and final finishing process.

Experienced sharp-sighted quality control engineer continuously checks and monitors at every level of activity. Thus every precision component that leaves JVMR bears unquestionable stamp of quality.



JVMR VISION & MISSION STATEMENT

JVMR believes that the foundation of its business is to provide excellence in its products through:
High Quality and Reliability.
Economical and Competitive Prices.
Efficient services to the satisfaction of the customers.

In order to achieve these goals and attain market leadership, it shall be the objective of every employee to strive to be.

“The Best in the Field”

JVMR QUALITY POLICY

JVMR has formulated the Quality Policy as stated below to exhibit its commitment to Quality, Reliability and Customer Satisfaction through continuous improvement.

To Strive for Excellence by:

Supplying Quality Products with high reliability at competitive price.

Providing efficient and prompt after sales service.

Achieving high degree of customer satisfaction through continuous improvement process.

Minimizing product cost while maintaining high quality and reliability.



PROMPT DELIVERY SCHEDULE

Just as our commitment to quality, JVMR pays equal importance to prompt deliveries. This has been paying us as good dividends in the form of repeat orders from our existing clients as well as recommendation to new clients.

DOCUMENTATION AND QUALITY CONTROL

Our documentation starts from receiving orders and ends with supply of quality product to our customers. All data right from incoming materials test reports, inspection certificates, etc. are recorded and maintained in proper way and the copy of these documents can be provided for customers reference if required.

RELATIONSHIP WITH THE CUSTOMERS

We are flexible and reliable with all our customers which has resulted in long standing relationship with our customers.



We need to grow, hence we need to build more customers and add capacity.

We are geared to take any challenging jobs of Precision Components, Jigs, Fixtures, MS & SS Fabrication works & Material Handling Equipments Conveyors, Trolleys etc.

We request you to provide an opportunity to serve your organization.

CERTIFICATIONS & COMPLIANCES



- VAT Registration – Yes
- Service Tax Registration – Yes
- PAN & TAN Registration – Yes
- SSI Registration – Yes
- NSIC Registration – Yes
- Peenya Industrial Association Member – Yes
- ICF & Other Railways Registration – Yes
- IREPS Registered Vendor - Yes
- ISO 9001-2008 Certified – Yes
- MSME Audited Vendor – Yes
- Rites Inspection – Yes
- KSPCB Clearance – Applied for
- Class 3 Digital Certificate - Yes

ISO 9001 - 2008 Certificate



Pictures of few Conveyors executed by us

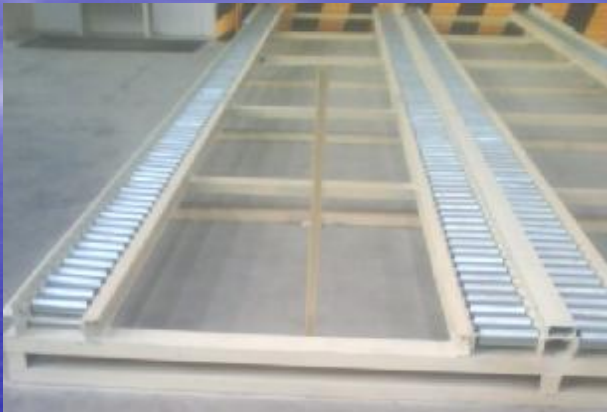

Pictures of Fuel Tank & Clamping fixtures
executed by us



**Pictures of Fuel Tank FRP Quoted, Seat Frames
Mirror Assy & Rigid Fixing bolts executed by us**



Pictures of Hydraulic Hearing & Bending Machine



Pictures of Compressor & Power Hack Saw



Pictures of Power Presses



Pictures of Buffing & Grinding Machine



Pictures of Drilling Machine & Lathe





Thank YOU